

PRO-60 HP PRO-110 HP

PUNZONATRICI OLEODINAMICHE PORTATILI



Caratteristiche principali e vantaggi:

- Cilindro Doppio Effetto- Processo completamente automatizzato di punzonatura e ritorno
- Vasta gamma di diametri di punzoni fino a 27 mm.
- Moderna costruzione
- Sistema di controllo intelligente con impulsi e rilevamento automatico del carico
- Spia modalità
- Protezione contro avviamenti fortuiti
- Facile da maneggiare in qualsiasi posizione
- Tutti gli attacchi situati sul retro
- Vasta gamma di punzoni e matrici speciali
- Compatta centralina idraulica mobile in attesa di brevetto
- Cavalletto di supporto che aumenta sia la produttività che il comfort dell'operatore

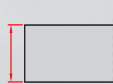

massimo spessore

PRO-60 HP

13 mm



massima profondità della gola

PRO-110 HP

16 mm



foro massimo

27 mm



foro ovale massimo

25 x 18 mm



tempo di punzonatura

5 sec



potere di foratura

35 Ton



doppio effetto movimento idraulico

YES

YES

Specifiche Tecniche della Punzonatrice Portatile Oleodinamica Doppio Effetto	modello PRO-60 HP	modello PRO-110 HP
Massima profondità gola	60 mm	110 mm
Massimo foro	Ø 27 mm	Ø 27 mm
Massimo Foro ovale	25 x 18 mm	25 x 18 mm
Tempo di ciclo	5 sec	8 sec
Spessore massimo	13 mm	16 mm
Potenza massima	35 ton	47 ton
Pressione massima	700 bar	700 bar
Peso	20 kg	35 kg
Codice per ordinazione	GLW-0522-10-00-00-1	GLW-0507-10-00-00-0

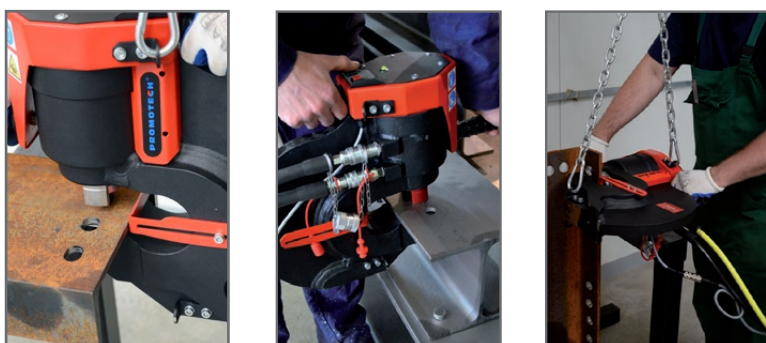

Possibilità di lavoro sia in verticale che in orizzontale.

Centralina Oleodinamica Doppio Effetto Modello HPP 700/1,5	
Alimentazione Elettrica*	230V/50Hz; 115V/60Hz
Potenza	2000 W
Pressione di lavoro	700 bar
Pompa Oleodinamica	1.5 L/min
Capacità serbatoio olio	10 L
Codice per ordinazione	ZSL-0517-10-20-00-0
	HPP-700/1,5 /220-240V/50Hz

*Contattateci per altre opzioni di tensione



Centralina con ripiano per il trasporto.



Dimensioni di ingombro

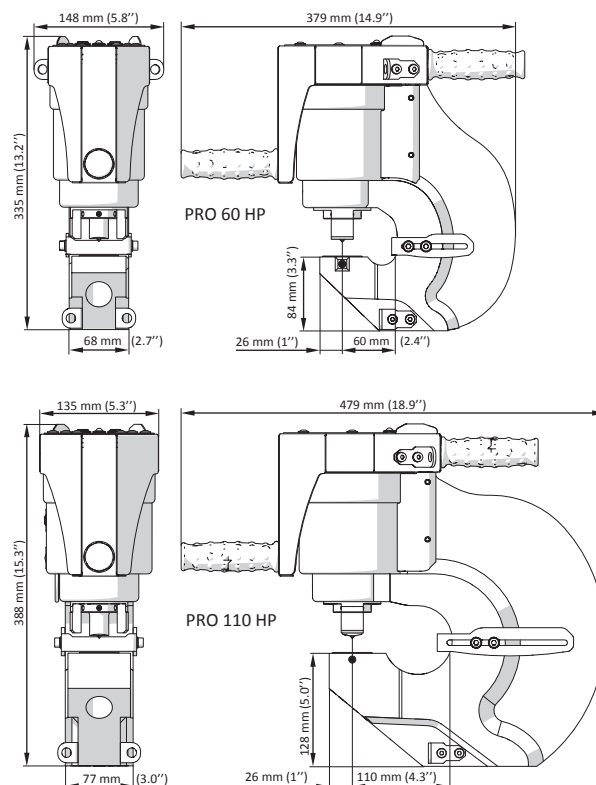

PRO-60 HP performances

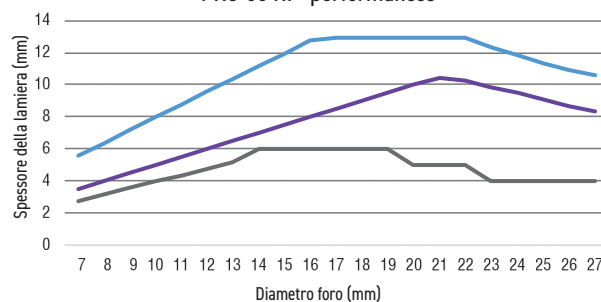

PRO-110 HP performances

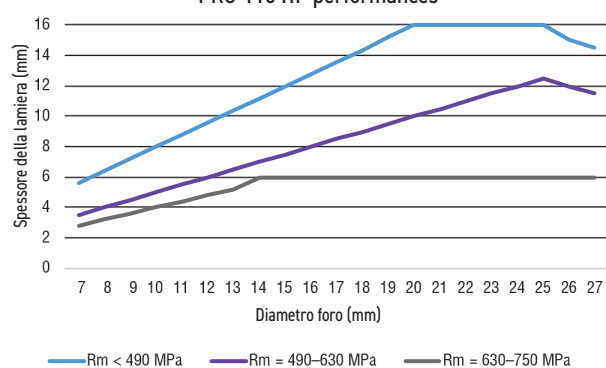

Bilanciatore per PRO-60 HP Codice prodotto: BLN-000004
Bilanciatore per PRO-110 HP Codice prodotto: BLN-000005

Accessori per personalizzare il vostro lavoro.

Set paranco

Codice per ordinazione: ZUR-0517-15-00-00-0

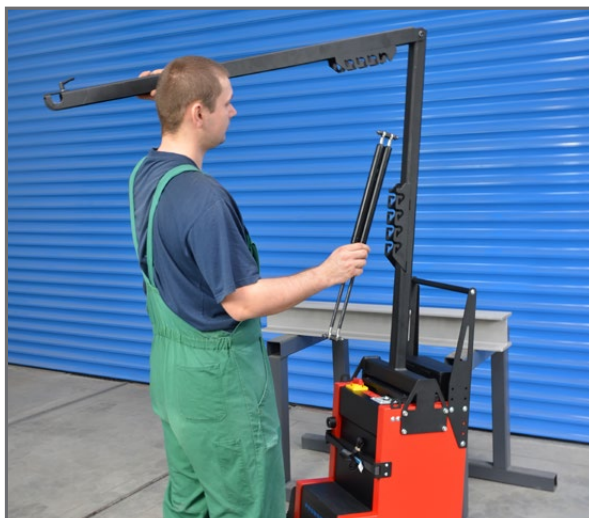

Semplice configurazione e facile regolazione di altezza.

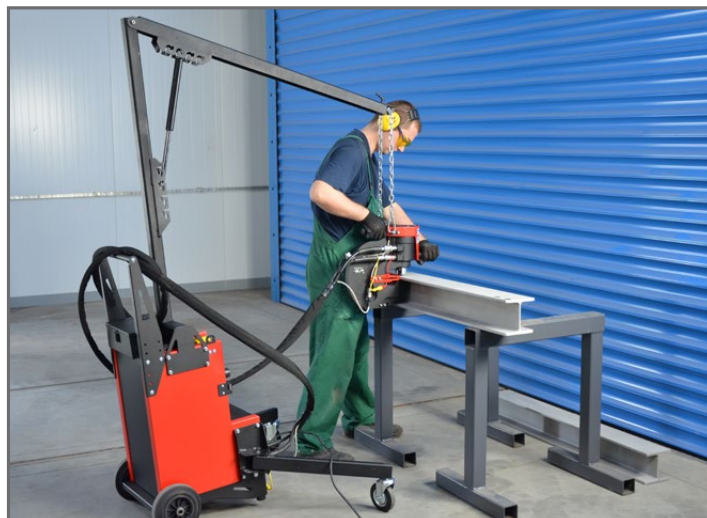

Braccio di sollevamento e 2 supporti con ruote consentono la facile movimentazione della punzonatrice e dell'unità oleodinamica.

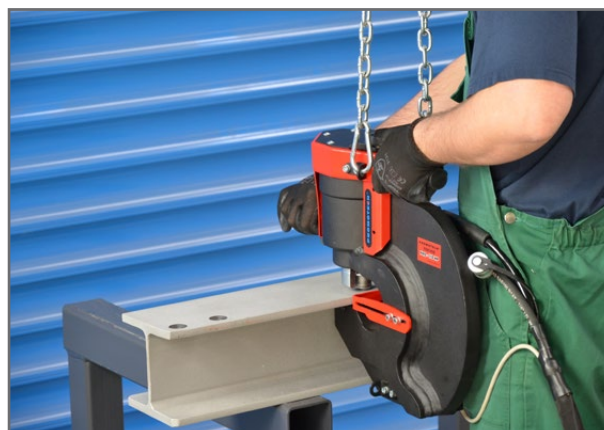
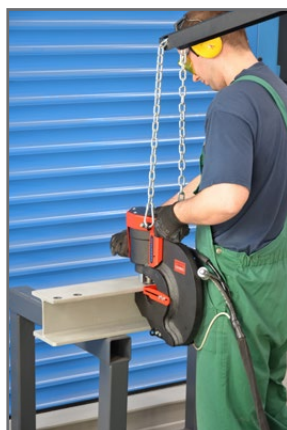

Un'unica soluzione per farti lavorare in modo più efficiente e confortevole.

Riscontro lineare con cuscinetti

Codice per ordinazione: PRW-0507-90-00-00-0

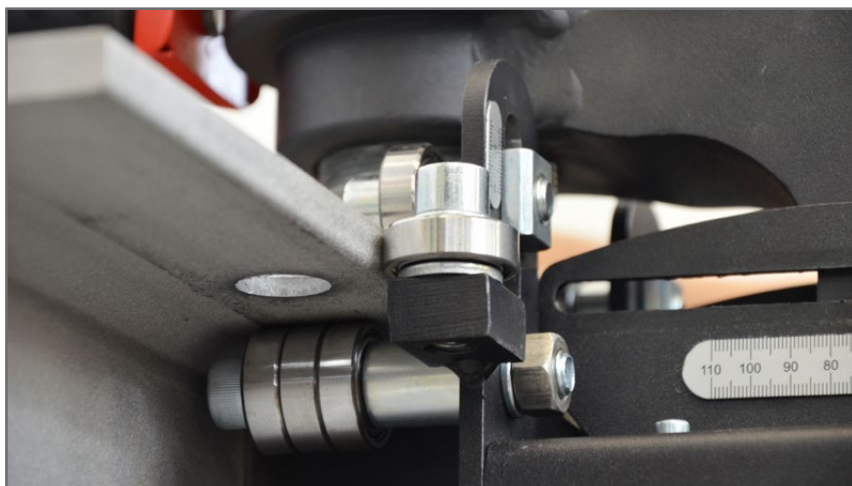

Permette un movimento lineare ed efficiente lungo il pezzo.



Supporto da banco con comando a pedale

Codice per ordinazione: ZST-0507-91-00-00-0



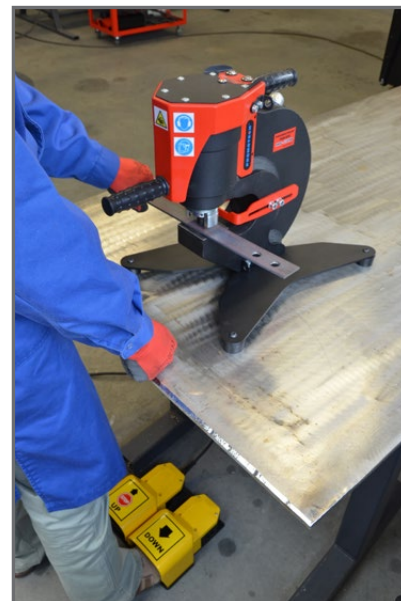

La punzonatrice può essere appoggiata su un banco e comandata da pedaliera.





Con il comando a pedale l'operatore può lavorare con le mani libere.

Punzoni e matrici

Utensili punzonatura		
Ovali [mm]	Punzone - codice prodotto	Matrice - codice prodotto
16x8	STM-0507-30-13-00-0	MTY-0507-70-13-00-0
18x9	STM-0507-30-12-00-0	MTY-0507-70-12-00-0
18x11	STM-0507-30-11-00-0	MTY-0507-70-11-00-0
20x10	STM-0507-30-10-00-0	MTY-0507-70-10-00-0
20x12	STM-0507-30-09-00-0	MTY-0507-70-09-00-0
20x14	STM-0507-30-08-00-0	MTY-0507-70-08-00-0
22x11	STM-0507-30-07-00-0	MTY-0507-70-07-00-0
22x14	STM-0507-30-06-00-0	MTY-0507-70-06-00-0
24x12	STM-0507-30-05-00-0	MTY-0507-70-05-00-0
25x9	STM-0507-30-04-00-0	MTY-0507-70-04-00-0
25x12	STM-0507-30-03-00-0	MTY-0507-70-03-00-0
25x13	STM-0507-30-02-00-0	MTY-0507-70-02-00-0
25x14	STM-0507-30-01-00-0	MTY-0507-70-01-00-0
25x16	STM-0507-30-17-00-0	MTY-0507-70-17-00-0
25x18	STM-0507-30-00-00-0	MTY-0507-70-00-00-0

A richiesta sono disponibili punzoni e matrici con misure speciali

Utensili punzonatura			
Diametri [mm]	Punzone - codice prodotto	Matrice - codice prodotto	Matrice 5° - codice prodotto
7	STM-0507-20-18-00-0	MTY-0507-40-18-00-0	-
8	STM-0507-20-17-00-0	MTY-0507-40-17-00-0	-
9	STM-0507-20-16-00-0	MTY-0507-40-16-00-0	MTY-0507-50-16-00-0
10	STM-0507-20-15-00-0	MTY-0507-40-15-00-0	MTY-0507-50-15-00-0
11	STM-0507-20-14-00-0	MTY-0507-40-14-00-0	MTY-0507-50-14-00-0
12	STM-0507-20-13-00-0	MTY-0507-40-13-00-0	MTY-0507-50-13-00-0
13	STM-0507-20-12-00-0	MTY-0507-40-12-00-0	MTY-0507-50-12-00-0
14	STM-0507-20-11-00-0	MTY-0507-40-11-00-0	MTY-0507-50-11-00-0
15	STM-0507-20-10-00-0	MTY-0507-40-10-00-0	MTY-0507-50-10-00-0
16	STM-0507-20-09-00-0	MTY-0507-40-09-00-0	MTY-0507-50-09-00-0
17	STM-0507-20-08-00-0	MTY-0507-40-08-00-0	MTY-0507-50-08-00-0
18	STM-0507-20-07-00-0	MTY-0507-40-07-00-0	MTY-0507-50-07-00-0
19	STM-0507-20-06-00-0	MTY-0507-40-06-00-0	MTY-0507-50-06-00-0
20	STM-0507-20-05-00-0	MTY-0507-40-05-00-0	MTY-0507-50-05-00-0
21	STM-0507-20-04-00-0	MTY-0507-40-04-00-0	MTY-0507-50-04-00-0
22	STM-0507-20-03-00-0	MTY-0507-40-03-00-0	MTY-0507-50-03-00-0
23	STM-0507-20-02-00-0	MTY-0507-40-02-00-0	MTY-0507-50-02-00-0
24	STM-0507-20-01-00-0	MTY-0507-40-01-00-0	MTY-0507-50-01-00-0
25	STM-0507-20-00-00-0	MTY-0507-40-00-00-0	MTY-0507-50-00-00-0
26	STM-0507-20-19-00-0	MTY-0507-40-19-00-0	MTY-0507-50-19-00-0
27	STM-0507-20-20-00-0	MTY-0507-40-20-00-0	MTY-0507-50-20-00-0

Tutte le informazioni possono essere soggette a modifiche senza alcun preavviso. 21.12



PROMOTECH Sp. z o.o.
ul. Elewatorska 23/1, 15-620 BIAŁYSTOK, POLAND
tel. (+48 85) 678 34 05, fax (+48 85) 662 78 77
marketing@promotech.eu www.promotech.eu

Rivenditore locale:

