

■ PRO-200A ATEX | PNEUMATIC DRILLING MACHINE

Heavy-duty pneumatic drilling machine with milling/cutting capacity up to 200 mm diameter and tapping capacity up to M48 is extremely useful for very special applications on construction sites and industrial installations, where electric appliances are prohibited for safety reasons.

Two permanent magnetic bases, pneumatic motor and no. 5 Morse Taper spindle make this machine one of the most powerful portable magnetic drills on the market.

PRO-200A ATEX is perfectly suited to hazardous environments such as oil drilling platforms, petrochemical plants, oil refineries, shipbuilding and petrochemical industry



■ Features & benefits:

- pneumatic motor and permanent magnetic bases eliminate the need of electric power supply
- intended for use in potentially explosive atmospheres
- heavy-duty pneumatic motor
- strong permanent magnets
- ATEX certified drill
- protection against accidental motor activation
- self-locking devices prevent any incidental deactivation of the permanent magnets
- cross slide system for precise hole center locations



PRO-200A ATEX conforms to II 2G Ex h IIC 135°C (T4) Gb and II 2D Ex h IIIB T135°C Db requirements for equipment used in hazardous environments



Core drill
max 200 mm
(7-7/8")



Twist drill
max 45 mm
(1-3/4")



Thread cutting
M48



Spindle
MT5



Depth of cut
100 mm
(4")



Stroke
400 mm
(15-3/4")



Speed
(under load)
20, 80 rpm



Motor Power
3650 W



Weight
130 kg
(290 lbs)

A potentially explosive atmosphere exists when a mixture of air gases, vapours, mists, or dusts combine in a way that can ignite under certain operating conditions. The source of ignition could be either electrical or mechanical in origin.

Working in explosive atmospheres carries many challenges, including first of all the safety of the workers. Therefore, PRO-200A ATEX complies with ATEX (ATmospheres EXplosibles) directive and is perfectly suited to hazardous environments such as oil drilling platforms, petrochemical plants, oil refineries, shipbuilding and petrochemical industry

PRO-200A ATEX capacity:

■ Milling up to 200 mm (7-7/8")



■ Drilling up to 45 mm (1-3/4")



ATTENTION: Cutter guard is not in place for demo purpose only

■ Tapping up to M48

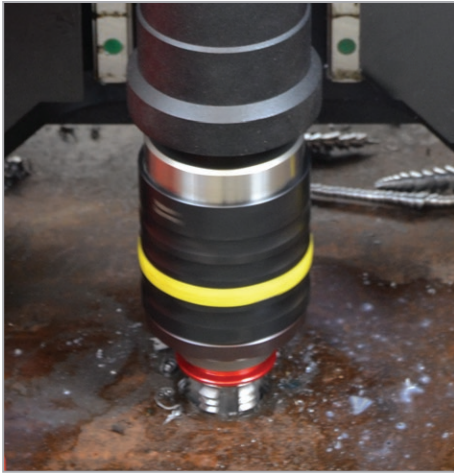

■ Optional accessories



MT5 tap chuck
OPR-00021



MT5 adapters for
M22 up to M48



MT4 tap chuck
OPR-00020



MT4 adapters for
M14 up to M38



MT5/MT4 sleeve
TLJ-000107



MT5/MT3 sleeve
TLJ-000169

Screw tap size	Adapter product code
M22-M26	ZBI-000027
M27	ZBI-000028
M29-M32	ZBI-000029
M33	ZBI-000030
M34-M38	ZBI-000031
M39-M42	ZBI-000032
M44-M48	ZBI-000033

Screw tap size	Adapter product code
M14	ZBI-000018
M16	ZBI-000019
M18	ZBI-000020
M20	ZBI-000021
M22-M26	ZBI-000022
M27	ZBI-000023
M29-M32	ZBI-000024
M33	ZBI-000025
M34-M38	ZBI-000026

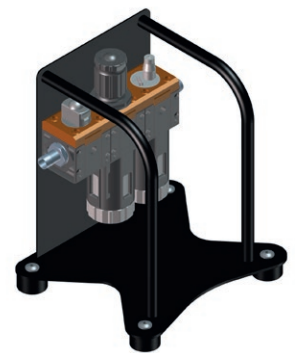

Air preparation unit
ZSP-0490-07-00-00-0

■ Working on contour surfaces



PRO-200A ATEX can be fixed to pipes of min. 950 mm (37.4") diameters

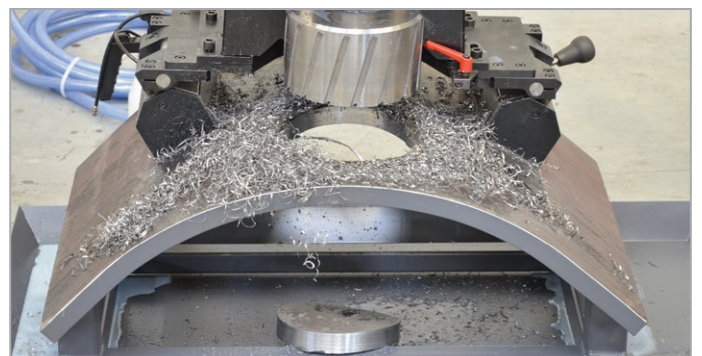

Base with permanent magnets can be adapted to a workpiece curvature

■ Safety features:

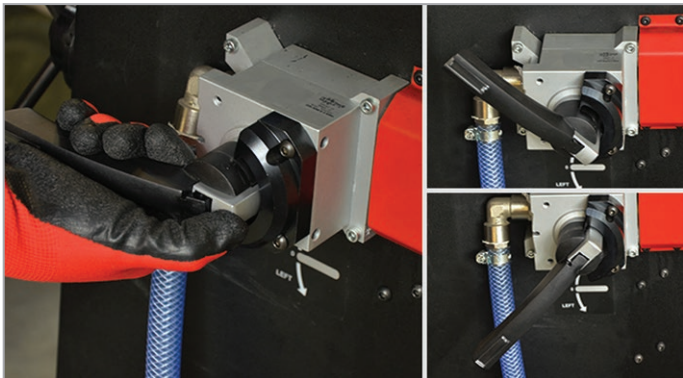

No accidental motor activation possible.
Operator must simultaneously press the button at the base of the lever and turn the valve lever until it stops, to enable motor start-up



Permanent magnets need no power supply from the mains.
A self-locking device prevents any possible accidental movement of the handle and deactivation of the magnet.

PRO-200A ATEX TECHNICAL SPECIFICATION	
Motor Speeds (under load)	20 rpm (gear I) 80 rpm (gear II)
Motor Power	3650 W
Air consumption	3500 l/min (125 CFM)
Pressure	6.5 bar
Air connection	G1/2" external thread
Spindle	MT5
Tool holder	31.75 mm Weldon (1-1/4")
Max milling capacity	200 mm (7-7/8")
Max drilling capacity	45 mm (1-3/4")
Max Tap size	M48
Stroke	400 mm (15-3/4")
Max depth of cut	100 mm (4")
Magnetic clamping force	2 x 1530 kgf (15000 N)
Min. workpiece thickness	13 mm (1/2")
Required ambient temperature	0-40°C (32-104°F)
Weight	130 kg (290 lbs.)
Product Code	WRT-0490-10-00-01-1

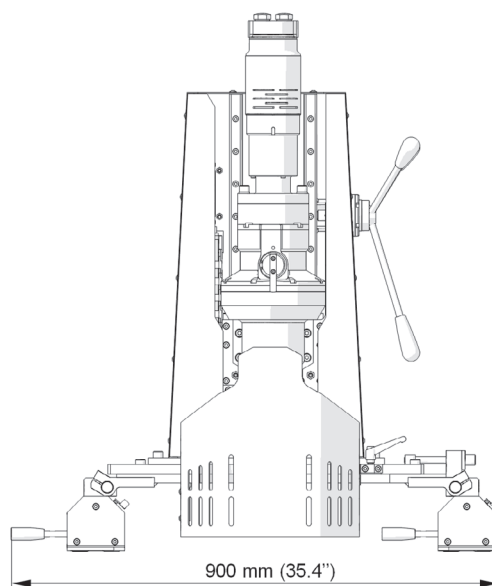
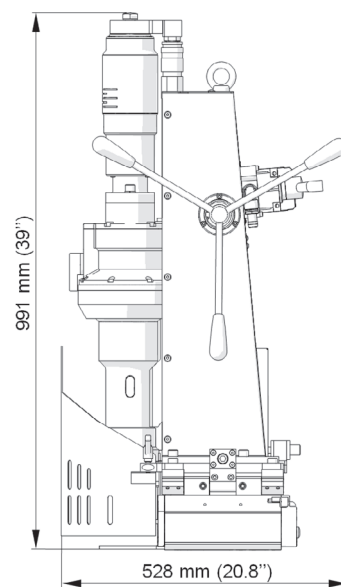

■ Standard set includes:

- pneumatic drilling machine
- MT5 arbor
- 3 feed levers
- cooling system 5l
- chip guard
- drift for MT5
- 4 mm hex wrench
- 5 mm hex wrench
- 6 mm hex wrench
- 8 mm hex wrench
- 10 mm hex wrench
- 13 mm flat wrench
- Operator's Manual

All information is subject to change without notice. 24.08



PROMOTECH Sp. z o.o.
ul. Elewatorska 23/1, 15-620 BIAŁYSTOK, POLAND
tel. (+48 85) 678 34 05, fax (+48 85) 662 78 77
marketing@promotech.eu www.promotech.eu

Your local dealer:

