

WA COMPACT | WELDING SYSTEM

The WA Compact Welding System is an advanced and versatile welding solution designed for making both continuous and stitch butt and fillet welds using the MIG/MAG method.

The system provides efficient joint tracking for active compensation of torch position vertically and horizontally with and without oscillation.

WA Compact supports welding with different oscillation patterns, including straight, triangle, trapezoid, and square, enhancing its adaptability to various welding tasks.

It is ideally suited for industrial applications, providing an efficient and budget-friendly option for workshops and large industrial plants.



Features and benefits:

- **Advanced Welding Capabilities:** Supports both continuous and stitch welding using MIG/MAG method, ensuring versatility in different welding tasks.
- **Precision and Efficiency:** Equipped with oscillation and joint tracking with motorized vertical slide, maintaining the correct torch position for high-quality welds.
- **Flexible Oscillation Patterns:** Offers various weld paths such as straight, triangle, trapezoid, and square, increasing adaptability to different requirements.
- **User-Friendly Control:** Ergonomic remote control pendant with simple and easy to find control knobs makes adjustments possible without lifting of the operator's welding hood.
- **Custom Track Length:** Track sections consists of 2,2 m support segments. The total length of the track can be tailored to the customer's requirements.
- **Cost-Effective Solution:** Budget-friendly advanced and versatile welding solution with customized workspace, making it a practical choice for both workshops and large industrial facilities.

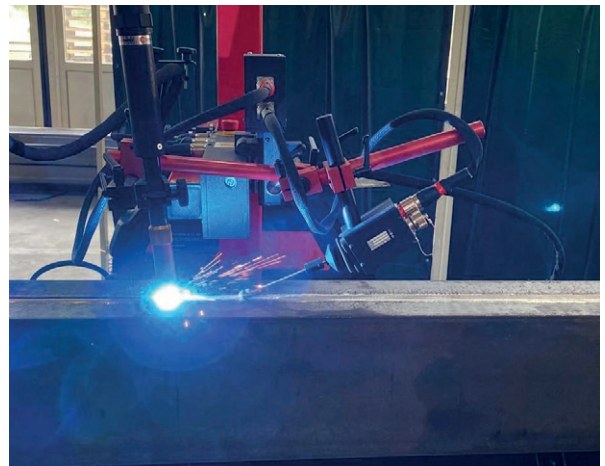

Welding joints:



WA Compact Oscillation Paths



Triangle. The machine travels only during oscillation. During oscillation dwell time, the machine stops to fill the crater.



Trapezoid. The machine travels at all times, also during oscillation dwell time.

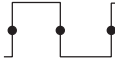

Square. The machine travels only during oscillation dwell time in left and right position. During oscillation, the machine stops. During oscillation dwell time in center position the machine fills the crater.



WA COMPACT TECHNICAL SPECIFICATION

Voltage	1~ 110-120 V, 50-60 Hz 1~ 220-240 V, 50-60 Hz
Power	200 W
Torch type	MIG/MAG
MIG/MAG torch diameter	16-22 mm (5/8"-55/64")
Horizontal speed	0,05-2,5 m/min (2-98 inch/min)
Oscillation type	Linear
Weld path	Straight, triangle, trapezoid, square
Oscillation width	0-11,4 cm (0-4 31/64")
Oscillation speed	0,1-2 m/min (4-79 inch/min)
Oscillation dwell time at center and on ends	0-5 s
Maximum oscillator pulling force	50 N
Allowed ambient temperature during operation	0-40°C (32-104°F)
Weight	950 kg (2095 lbs)

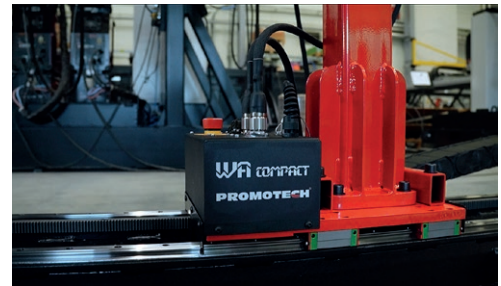
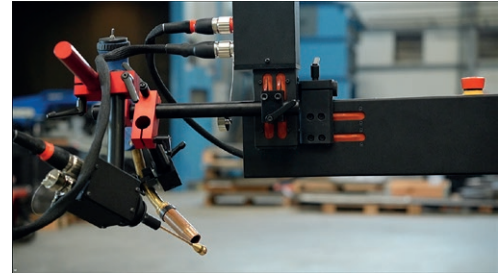

Standard shipping set:

- Gantry welding system
- Customised track (multiplication of 2.2m long section)
- Arc ignition cable
- Remote control pendant
- Remote control cable 0.8 m (2.6 ft)
- Remote control cable 1 m (3.3 ft)
- Remote control cable 3 m (9.8 ft)
- Remote control cable 10 m (32.8 ft)
- Vertical slide
- Tracking sensor
- Fork tracking tip
- Torch holder
- Rod
- Long oscillator holder
- Rod clamp (2 pcs)
- Clamping block (2 pcs)
- 2 mm hex wrench
- 1.5 mm hex wrench
- Operator's manual

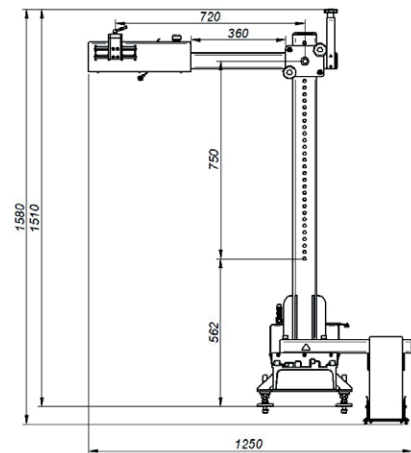

Mitglied im DVS - Deutscher Verband für Schweißen und verwandte Verfahren e. V.



More information available at www.promotech.eu



PROMOTECH Sp. z o.o.
ul. Elewatorska 23/1, 15-620 BIAŁYSTOK, POLAND
tel. (+48 85) 678 34 05, fax (+48 85) 662 78 77
marketing@promotech.eu www.promotech.eu

Your local dealer:

