

## ■ LIZARD | PROGRAMMABLE WELDING TRACTOR

Lizard is a portable, programmable, trackless welding tractor designed to produce consistently high-quality welds.

It can be programmed in continuous or stitch welding modes.

Welder-friendly two-function buttons enable storage and reproduction of up to 40 different welding programs for various joint configurations and multi-pass, multi-layer welds.

Constant, continuous, and repeatable travel speed enables weld bead geometry that is exact to the required specifications, thus reducing costly over welding and decreasing filler metal usage, substantially.

Lizard is capable of producing weave welds by means of an optional pendulum oscillator. The oscillator allows for precise control of weave width, weave speed, and left/right side wall dwell and is particularly useful for vertical welding.

**42V AC** version available

### ■ Applications:

- Trailer manufacturing
- Truck tanks
- Oil tanks
- Water storage tanks
- Transformers
- Shipyards
- Any application demanding stitch or a long, continuous fillet weld



### ■ Primary features and benefits:

- Up to 40 complete programs may be stored in non-volatile memory to repeat optimum weld procedures
- Multifunctional LCD and 2-function buttons for programming selected welding patterns and parameters such as weld length, the distance between welds, reverse fill, crater fill time, and others
- The closed-loop speed control system stabilizes travel speed, enabling uniform heat input to produce consistently high-quality welds
- Lizard travels at full speed between stitches, which saves valuable welding time.
- The optional torch oscillator produces weave welds
- 4-wheel drive magnetic traction permits out-of-position use
- Compact, lightweight design with a durable aluminum cast housing
- Convenient Power Supply 115–230 V, 50–60 Hz or 42 V, 50–60 Hz



### Optional Pendulum Oscillator

Oscillator features precise control of weave width, weave speed and dwell times.



Programming device up to 40 welding programs



Dual Arc Ignition

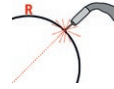

Min. path convex radius 1500 mm (5 ft)



Angular oscillation

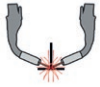

Dual torch welding

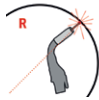

Min. path concave radius 1500 mm (5 ft)



Continuous welding

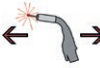

Horizontal speed 0-130 cm/min (0-51 3/16 in/min)



Weight 14 kg (31 lbs)



Stitch welding



Vertical speed 0-120 cm/min (0-47 1/4 in/min)

### Versatility of applications including out-of-position use

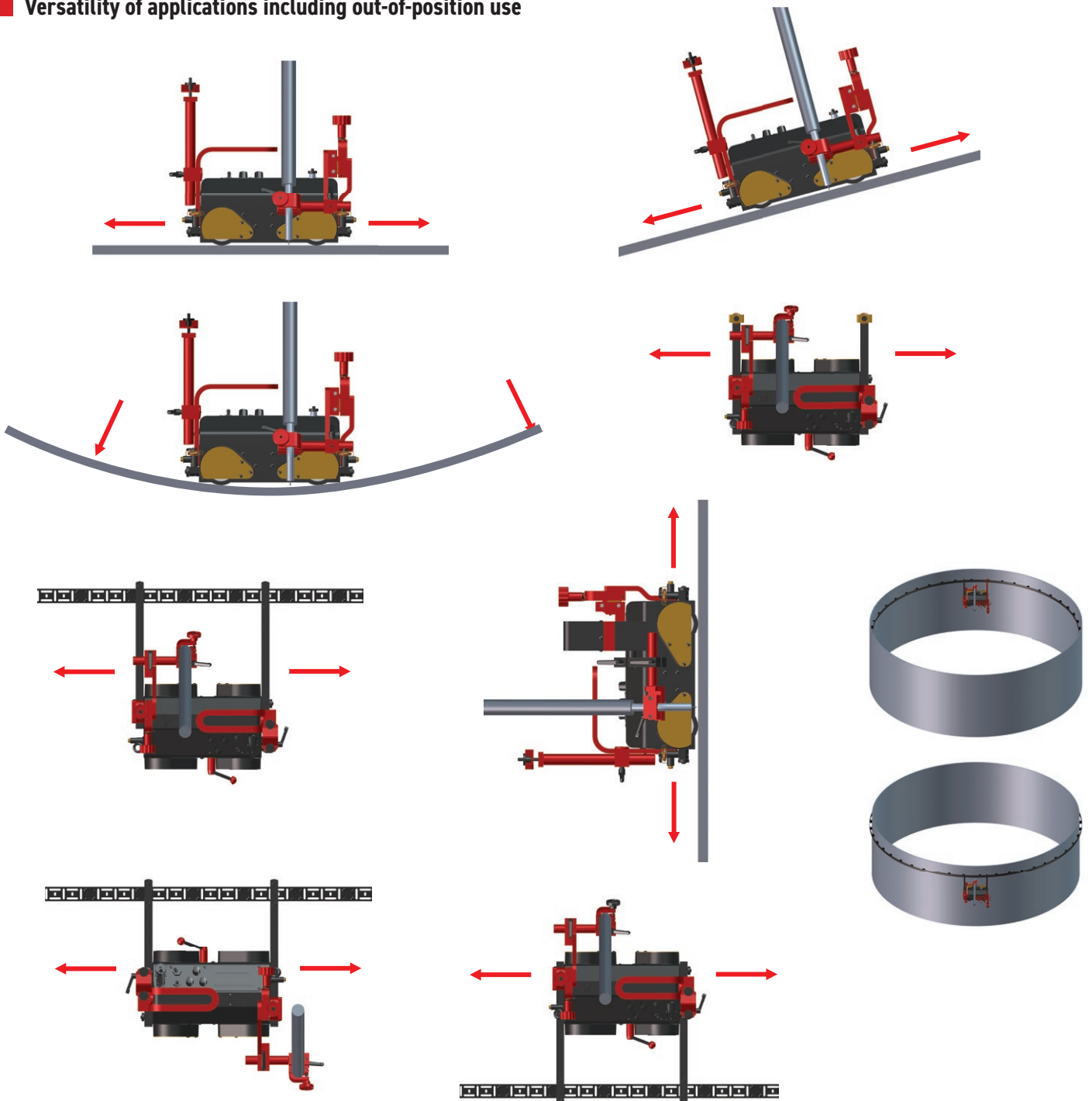

## More features and benefits:

- Positive magnetic traction permits out of position use
- Magnet on/off lever permits easy set up and adjustment on work piece
- Heat resistant silicone wheels
- Quick clamping Torch Holder mechanism for different types of MIG/MAG torches with diameters of 16-22 mm (5/8" - 7/8"); optionally up to 35 mm (1-3/8")
- Precise torch adjustment with screw drive cross slide
- Consistent heat input reduces distortion
- Reduced wasted filler metal - eliminates over welding
- Automatic arc on/off system initiates welding and travel, simultaneously
- Capable of carrying and controlling 2 torches (without oscillation)
- Self-guiding roller arms eliminate the need for track
- Multi-surface guiding

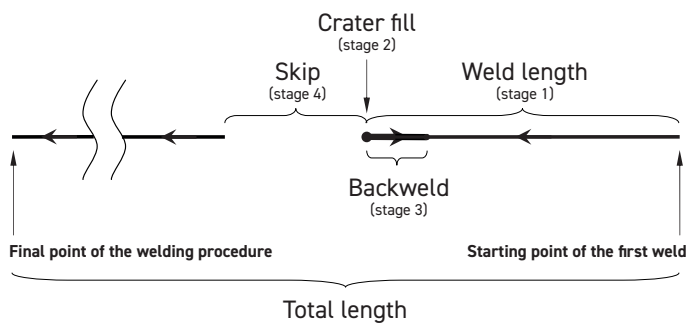

Programmable variables diagram

1. Operator's panel with control knobs and switches
2. Limit switch
3. Adjustable guide arm
4. Quick clamp torch holder
5. Cross slide assembly
6. Cable anchor
7. Main Power Switch (0/I)
8. Weld contact / Arc ignition socket
9. Magnetic adhesion release lever

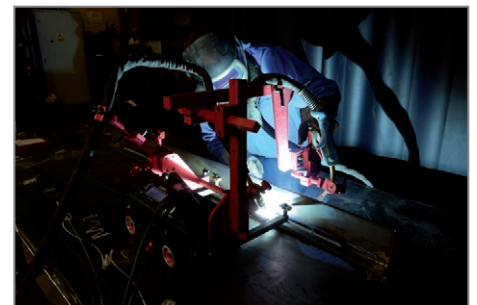
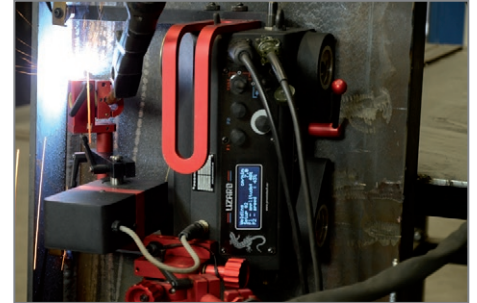

**Standard accessories**



Standard guide arms (set of 2 pcs)  
PRW-0476-56-00-00

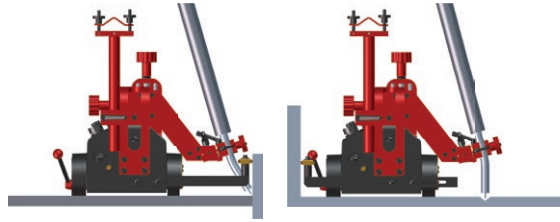

Cable anchor  
PDT-0754-12-00-00



Dual arc ignition cable of 6.5 m (21 ft)  
KBL-0466-17-00-00



Short rod torch holder  
with clamp 16-22 mm  
UCW-0754-07-00-00

**Optional accessories for variety of applications**



Torch clamp 16-22 mm  
ZRX-0752-07-01-00-0



Torch clip 16-22 mm  
ZCS-0476-06-01-00-0



Torch clamp 22-35 mm  
ZRX-0466-19-00-00-0



Short Rod Clamp  
WLK-0476-20-01-00-0



Short rod torch holder  
with clip 16-22 mm  
UCW-0476-27-00-00-0



Long Rod Clamp  
WLK-0466-04-10-00-0



Long rod torch holder  
with clamp 16-22 mm  
UCW-0752-07-00-00-0



Long rod torch holder  
with clip 16-22 mm  
UCW-0466-22-00-00-0

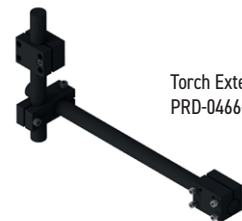

Torch Extension Arm  
PRD-0466-43-00-00-0



Dual Torch Mount  
PDT-0466-40-00-00-0

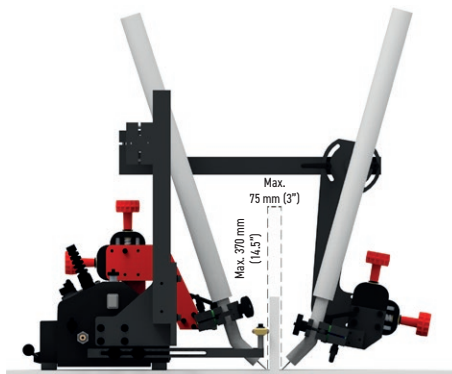

Extended cross-slide  
0-76 mm (0-3") up-down,  
0-35 mm (0-1.38") left-right  
ZSP-0466-46-00-00-1



Fall arrester device  
URZ-000001

## Optional accessories for multi-surface guiding and variety of applications

Guide arms enable a proper welding tractor positioning.

- 7 different guide types are dedicated to various welding applications and positions
- include a number of fixing grooves for your convenience
- enable simpler, easier and more consistent adjustment of how guide arms stick out
- secure proper tilting of the tractor into a direction of its movement
- maintain a permanent contact with the workpiece
- allow either interval or continuous guide arms adjustment

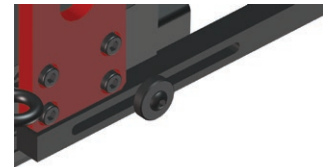
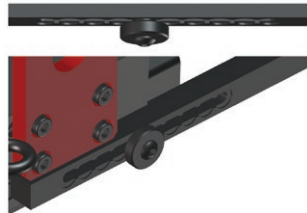

Each new guide arm has got a number of indented grooves only on one side.

All types of guide arms are available in pairs of 2 pcs: right and left.

Interval adjustment of a degree how much the guide arms stick out

Continuous adjustment of a degree how much the guide arms stick out

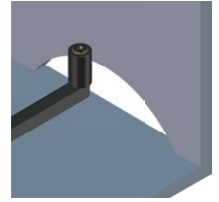
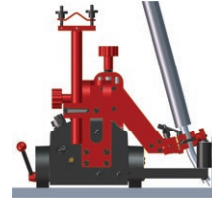
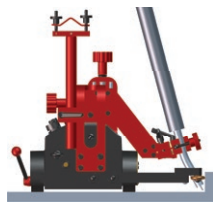

Low Guide Arms (set of 2 pcs)  
PRW-0476-54-00-00-1

High Guide Arms (set of 2 pcs)  
PRW-0476-55-00-00-1

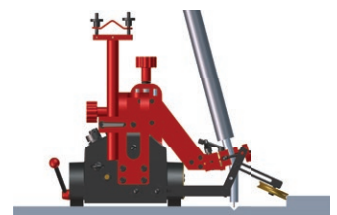
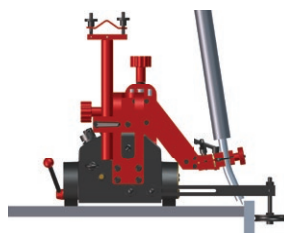

Edge Following Guide Arms (set of 2 pcs)  
PRW-0476-21-00-00-1

Adjustable Guide Arms (set of 2 pcs)  
PRW-0476-22-00-00-1

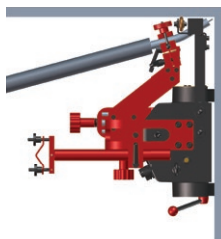

Display shield  
OSL-0476-23-00-00-0

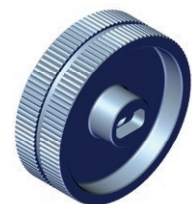

Stainless steel driving wheel  
KOL-0476-57-00-00-0

Magnet guide arms (set of 2 pcs)  
PRW-0476-52-00-00-1



Track Following Guide Arms (set of 2 pcs)  
PRW-0476-50-01-00-1

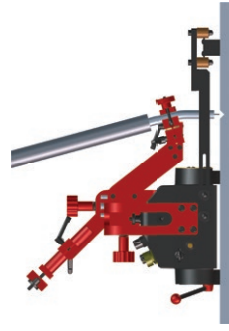
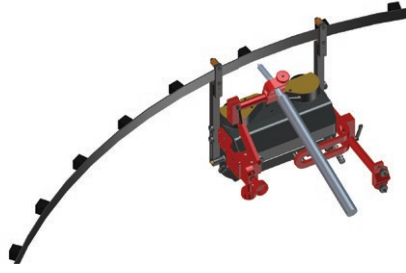

Guide adjustment tool to position the track parallel to the edge  
UST-0466-53-00-00-0

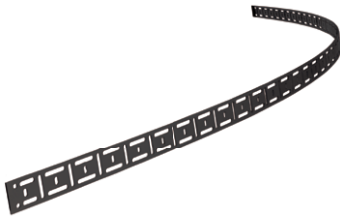

Flexible Track 185 cm (6ft) 1 pc  
PRW-0466-50-01-01-0



Magnetic block for flexible track  
box of 10 pcs  
BLO-0466-68-00-00-0

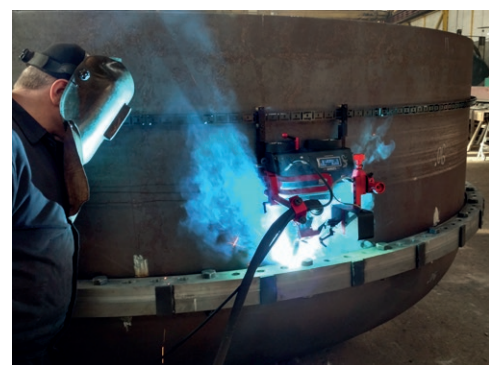
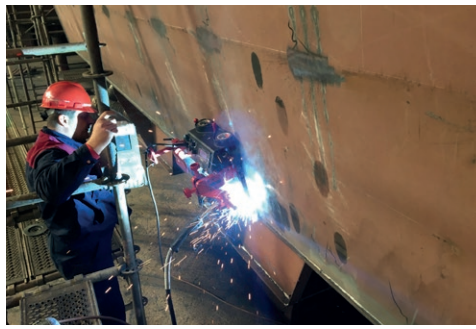
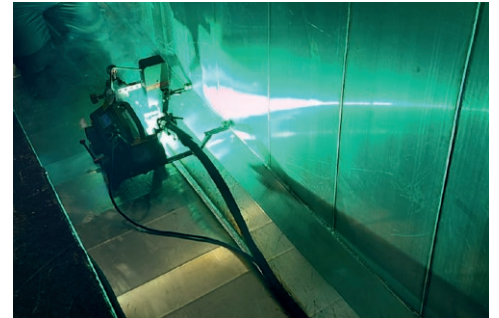
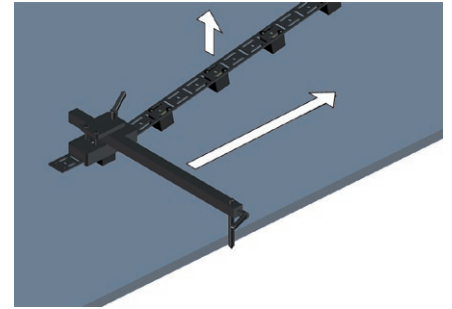

**Optional  
Pendulum Oscillator**

The oscillator features precise control of weave width, weave speed and dwell times.



Oscillator  
ZSP-0477-10-00-00



Torch Holder Lower Rod Clamp Assembly  
UCW-0476-06-00-00

Oscillator settings diagram

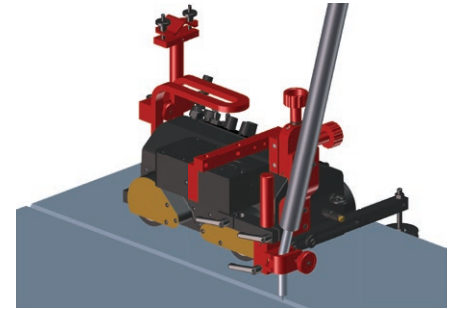
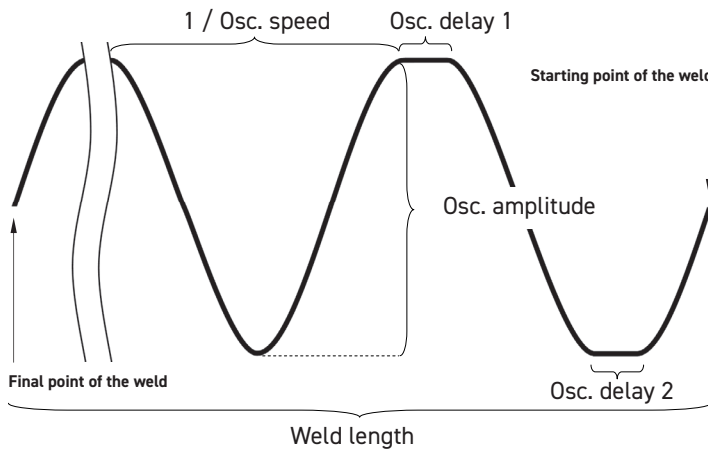

Butt joint welding with oscillator



Fillet Welding with oscillator

Oscillation type	pendulum (0°-11°)
Oscillation amplitude	1-30 mm (1-100%) at r=150 mm (5.9")
Oscillation speed at oscillation amplitude of 10 mm (25/64") and zero dwell time on ends	7-164 cycles/min (1-100%)
Oscillation delay time	0-5 s (at external points)
Power	12 W
Weight	2.6 kg (5.7 lbs)

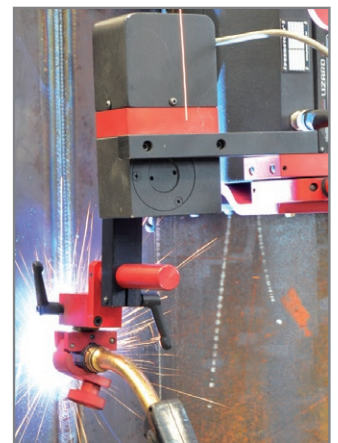

## TECHNICAL SPECIFICATIONS LIZARD

Voltage	1~ 115-230 V, 50-60 Hz 42 V, 50-60 Hz
Power	25 W
Welding position (according to EN ISO 6947 and AWS/ASME)	PA / 1F / 1G PB / 2F PC / 2G PD / 4F PE / 4G PF / 3F / 3G with optional oscillator) PG / 3F / 3G (with optional oscillator)
Programmable variables	tractor speed, weld length, skip, crater fill, backweld, total length
Welding settings storage	up to 40
Menu language	English, French, German, Polish, Portuguese, Russian, Spanish, Turkish
Torch diameter	16-22 mm (0.63-0.87"); up to 35 mm (1.38") option
Minimum radius of curved workpiece surface	1500 mm (5 ft)
Minimum workpiece thickness	5 mm (0.2")
Ground clearance	5 mm (0.2")
Horizontal pulling force	220 N
Vertical pulling force	150 N
Cross slide adjustment range	0-35 mm (0-1.38") up-down, left-right
Horizontal speed	0-130 cm/min (0-51 3/16 in/min)
Vertical speed	0-120 cm/min (0-47 1/4 in/min)
Limit switch	at both sides
Weight	14 kg (31 lbs)
Product Code (115-230 V, 50-60 Hz, plug EU)	WOZ-0754-10-20-02-0
Product Code (115-230 V, 50-60 Hz, plug UK)	WOZ-0754-10-10-03-0
Product Code (42 V, 50-60 Hz)	WOZ-0784-10-42-01-0

### Standard shipping set:

- Lizard tractor
- Standard guide arms (set of 2 pcs)
- Short rod torch holder with clamp 16-22 mm
- Cable anchor
- Dual arc ignition cable of 6.5 m (21 ft)
- 4 mm hex wrench
- Plastic box
- Operator's manual

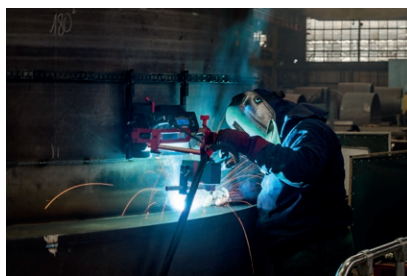

### Dimensions:

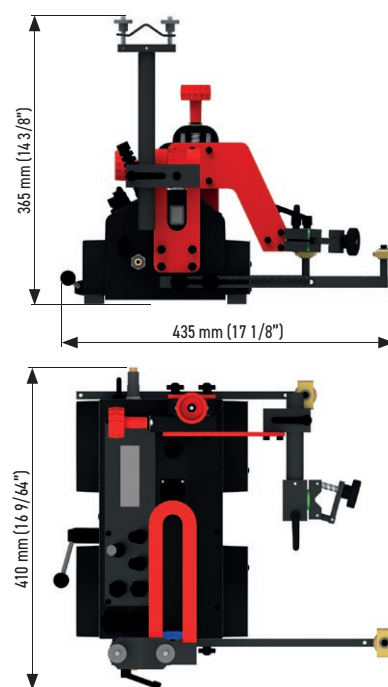

More information at  
[www.promotech.eu](http://www.promotech.eu)

 **American Welding Society**  
Supporting Company Member

Mitglied im DVS - Deutscher Verband für  
Schweißen und verwandte Verfahren e. V.  
 **DVS** VERBAND

All information is subject to change without notice. 24.10



PROMOTECH Sp. z o.o.  
ul. Elewatorska 23/1, 15-620 BIAŁYSTOK, POLAND  
tel. (+48 85) 678 34 05, fax (+48 85) 662 78 77  
marketing@promotech.eu www.promotech.eu

Your local dealer:

