

PRO-2 PB | COMPACT PIPE BEVELLER

PRO-2 PB is a compact, handy pipe beveler that mills pipes made of carbon and stainless steel, aluminum alloys, and copper-nickels. The machine can face off and bevel pipes from inner diameters (ID) of 19.5 mm (0.77") to outer diameters (OD) of 48 mm (1.89").

Small pipes from ID 15.5 mm (0.61") up to OD 29 mm (1.14") can be beveled with optional small mandrel set.

PRO-2 PB is able to mill also larger pipes from ID 38 mm (1.50") up to OD 60.3 mm (2.37") by means of an optional extension set.

Its exceptionally narrow housing (only 48 mm wide) makes it perfectly suited to space restricted areas such as boiler water walls.

PRO-2 PB incorporates overload systems incl. wet multi-disk friction clutch to prevent gear damage if the tool gets stuck.



3 different sources of power to choose from:



Max wall thickness up to 8 mm (0.32")

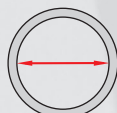

ID 19.5 - 38 mm (0.77 - 1.50")
ID 15.5 - 22 mm (0.61 - 0.87") /option/
ID 38 - 58 mm (1.50 - 2.28") /option/



Facing off



Pipe OD beveling
up to 48 mm (1.89")
up to 60.3 mm (2.37") /option/

TECHNICAL SPECIFICATION	PRO 2 PB with air motor	PRO 2 PB with electric motor	PRO 2 PB with battery motor
Air requirement	0.6 MPa (87 psi)	-	-
Air consumption	1600 l/min (56.5 CFM)	-	-
Voltage	-	1 ~ 220-240 V, 50-60 Hz	18 V DC
Power	800 W	1100 W	-
Connection	CEJN 410 DN 10.4 R 1/2" BSPT fitting for quick-coupling	Electrical plug	Battery connection
Nominal rotational speed	105 rpm	10-134 rpm (gear 1) 30-377 rpm (gear 2)	10-60 rpm (gear 1) 30-205 rpm (gear 2)
Pipe diameter	19.5 mm ID-48 mm OD 15.5 mm ID-29 mm OD* 38 mm ID-60.3 mm OD**	19.5 mm ID-48 mm OD 15.5 mm ID-29 mm OD* 38 mm ID-60.3 mm OD**	19.5 mm ID-48 mm OD 15.5 mm ID-29 mm OD* 38 mm ID-60.3 mm OD**
Maximum pipe wall thickness	8 mm 3.5 mm*	8 mm 3.5 mm*	8 mm 3.5 mm*
Weight with motor	7.6 kg (17 lbs)	7.4 kg (16.5 lbs)	6.5 kg (14.5 lbs), includes battery

* With an optional small mandrel set (ZST-0731-03-00-00-0).

** With an optional extension set (ZST-0731-02-00-00-0).

Standard shipping set:

- Beveling machine (without motor, tool bits)
- Plastic box
- Standard self-centering expandable mandrel for pipe ID \varnothing 19.5 - 38 mm (0.77-1.50")
- 4 sets of spreaders and 4 expansion sleeves for standard mandrel
- Tool bit holder
- Handle
- Set of tools
- Tool box
- Coolant container with nozzle
- Operator's manual



Dimensions

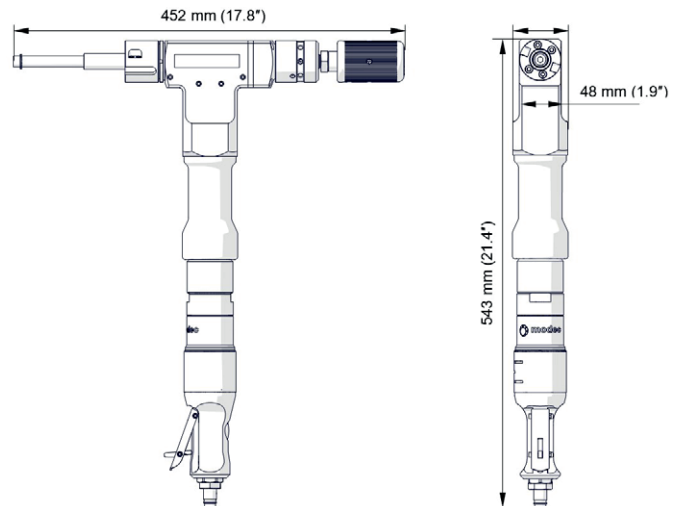

PRO 2 PB with pneumatic motor

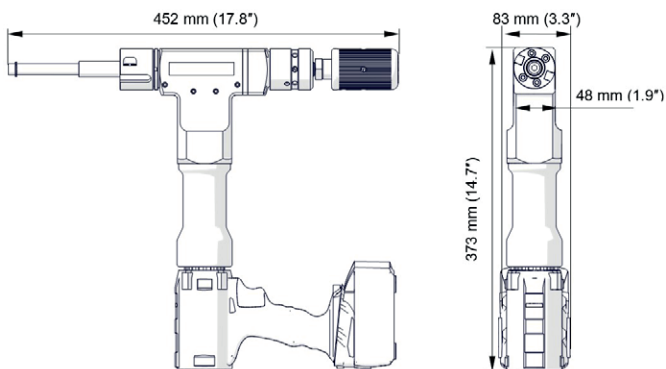

PRO 2 PB with battery motor

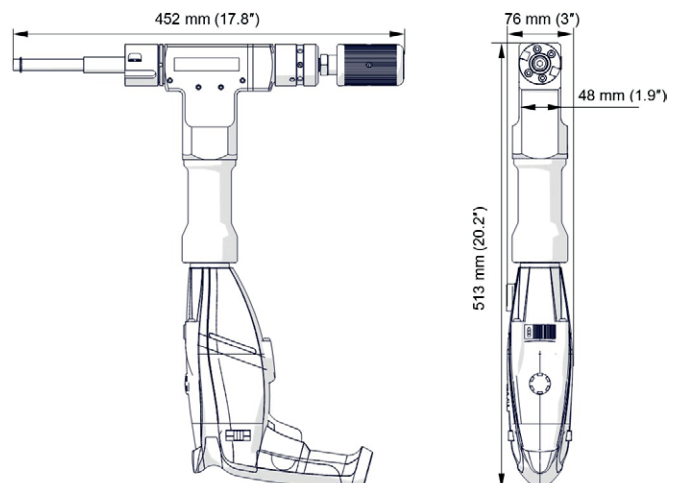

PRO 2 PB with electric motor

Optional accessories:

Pneumatic motor
NPD-0472-03-00-00-0



Adapter and driver
ZST-0567-24-00-00-0



Electric motor
SLN-000238 (230 V)



Driver
ZBI-0567-25-00-00-0



Driver
ZBI-0567-26-00-00-0



Battery
brushless drive
WRT-000024



Battery 4.0 Ah
AKM-0738-10-00-01-0



Battery 5.5 Ah
AKM-0738-10-00-03-0



Battery 10.0 Ah
AKM-0738-10-00-02-0



Battery charger with built-in Air-Cooled system
LDW-0738-10-00-30-0 (EU)
LDW-0738-04-00-30-0 (UK)

Charging time: ~ 30 min (4.0 Ah)
~ 41 min (5.5 Ah)
~ 74 min (10.0 Ah)



Air preparation set
ZST-000021



HD-CUT OIL 1 - tapping, drilling and
machining fluid
OLJ-0505-09-00-00-0 (0.5 kg)
OLJ-0505-10-00-00-0 (1.0 kg)
OLJ-0505-11-00-00-0 (5.0 kg)

Tool bits:

NOZ-000071 for steel	0° facing tool bit short	
NOZ-000078 for stainless steel	0° facing tool bit short*	
NOZ-000072 for steel	0° facing tool bit long	
NOZ-000079 for stainless steel	0° facing tool bit long*	
NOZ-000073 for steel	30° beveling tool bit	
NOZ-000080 for stainless steel	30° beveling tool bit*	
NOZ-000074 for steel	37.5° beveling tool bit	
NOZ-000081 for stainless steel	37.5° bevelling tool bit*	
NOZ-000075 for steel	45° beveling tool bit	
NOZ-000082 for stainless steel	45° beveling tool bit*	

*Tool bits for stainless steel feature TiAlN coating

Small mandrel set for pipes from
ID 15.5 mm (0.61") up to OD 29 mm (1.14")
ZST-0731-03-00-00

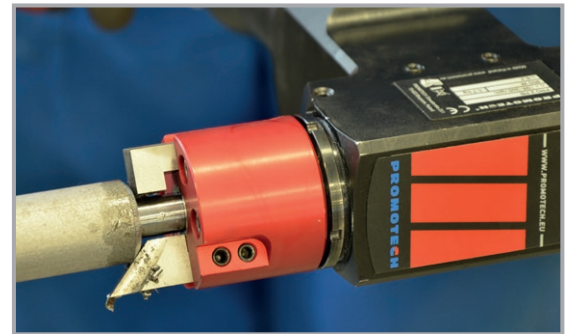
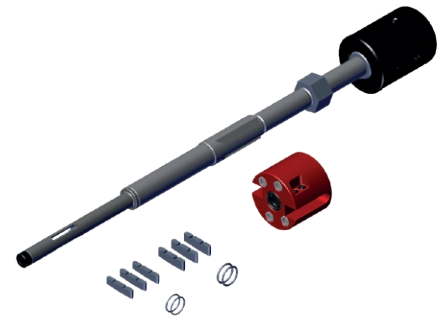

Extension set for pipes from
ID 38 mm (1.50") up to OD 60.3 mm (2.37")
ZST-0731-02-00-00

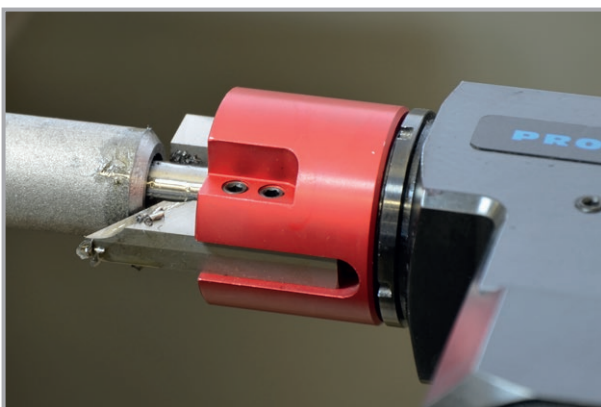

All information is subject to change without notice. 25.02



PROMOTECH Sp. z o.o.
ul. Elewatorska 23/1, 15-620 BIAŁYSTOK, POLAND
tel. (+48 85) 678 34 05, fax (+48 85) 662 78 77
marketing@promotech.eu www.promotech.eu

Your local dealer:

