

RAIL TUG | TRACK WELDING AND CUTTING TRACTOR

The Rail Tug is a digitally controlled tractor designed for the mechanization of welding and thermal cutting processes. Featuring a rack and pinion drive system with electronic speed control, Rail Tug creates weld bead geometry which is exact to your specifications, reducing costly over welding and decreasing filler metal usage.

It can be used with semi-flexible tracks for plate and tank work with a minimum radius of 5 m (16 ft) or adapted to bent ring rail for pipe and tube applications.

Hi Flex tracks are suitable for variety of circumferential and irregular surface applications down to minimum radius of 750 mm (30")

Standard ring tracks are available for tube diameters from 200 mm (8") up to 3000 mm (10 ft).

Using a vacuum system allows the tracks to be clamped to non-ferrous surfaces (stainless steel, aluminum etc.)

The Rail Tug economically meets a broad array of welding and cutting applications on flat or curved plate, tube and pipe.

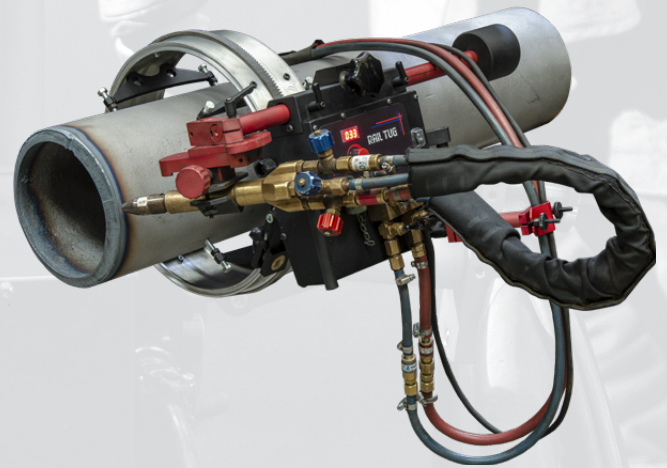

Applications:

- Trailer manufacturing
- Truck tanks
- Oil tanks
- Water storage tanks
- Pressure vessels
- Bridge girders
- Structural steel
- Structural towers
- Panel welding
- Transformers
- Shipyards
- Any application demanding long continuous welds

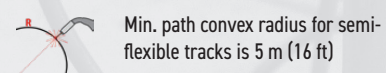
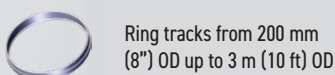
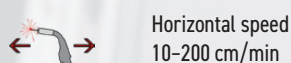

Rail Tug can work in various welding positions on both ferromagnetic and non-ferromagnetic materials by using rack and pinion drive and various tracks equipped with magnetic or vacuum units.

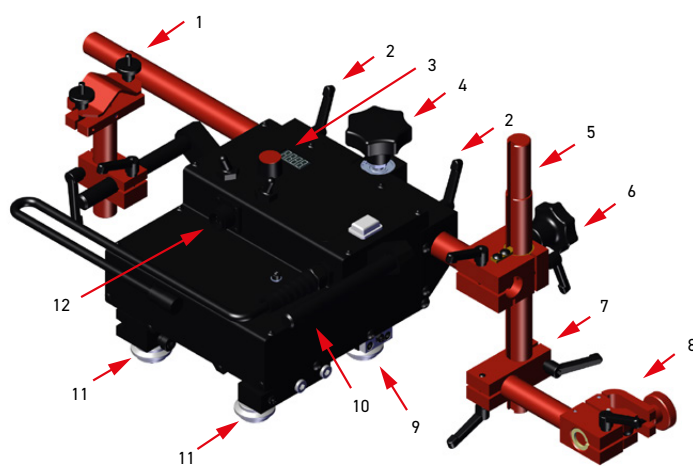
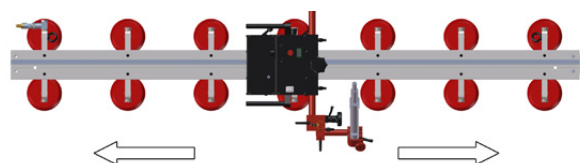
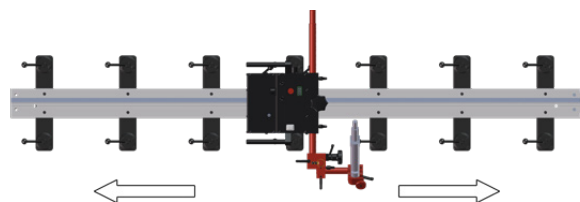
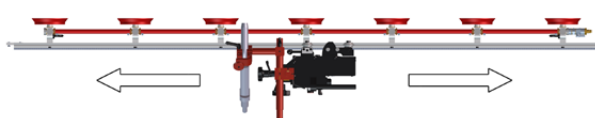
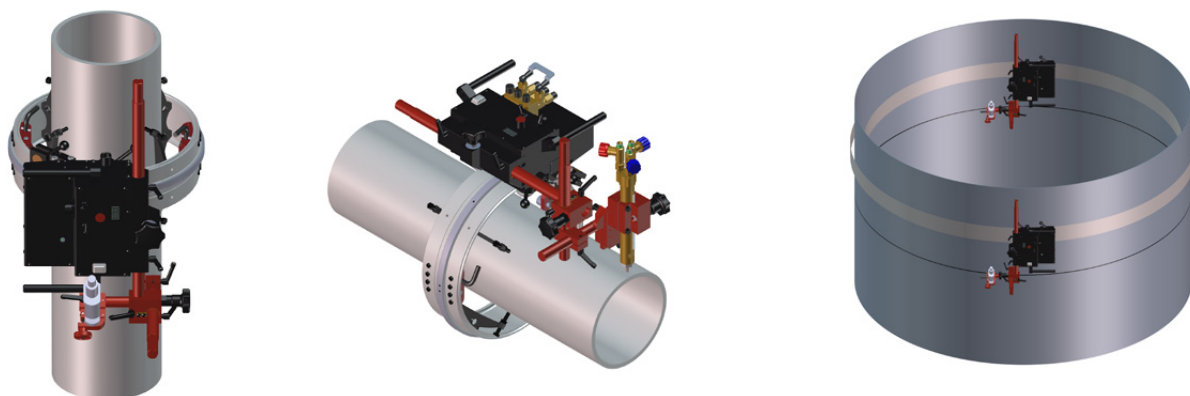

- | | |
|--|---|
| 1. 540 mm (21") rack | 7. Clamping block with levers |
| 2. Rack Locking Levers | 8. Short rod torch holder with fits-all clamp |
| 3. Control panel | 9. Guiding Roller |
| 4. Rack adjustment knob | 10. Carrying handle |
| 5. 300 mm (12") rack with 180 mm (7") adjustment | 11. Adjustable Roller |
| 6. Rack holder | 12. Arc ignition socket |



■ Primary features and benefits

- Compact, lightweight design
- Closed-loop speed control system based on electric motor with encoder – ensures increased accuracy of speed
- Rack and pinion drive
- Consistent heat input reduces distortion
- Reduces wasted filler metal – eliminates over welding
- Digital LED display for presetting of travel speed
- Automatic arc on/off initiates welding and travel simultaneously
- Oxy-fuel and plasma cutting possible with optional accessories
- Suitable for variety of circumferential and irregular surface applications down to minimum radius of 100 mm (4")
 - Ring tracks on diameters from 200 mm (8") OD up to 3 m (10 ft) OD
 - Hi-Flex tracks on diameters from 1500 mm (59") OD upwards
 - Semi-flexible tracks can be bended to minimum radius of 5 m (16 ft) without permanent deformation
- Quick-clamping torch holder mechanism for different types of torches with diameters of 16–22 mm (0.63–0.87"); up to 35 mm (1.38") option
- Precise torch adjustment with screw drive cross slide
- Convenient external 85-250 V power supply
- Improves working environment – removes operator from heat and fumes

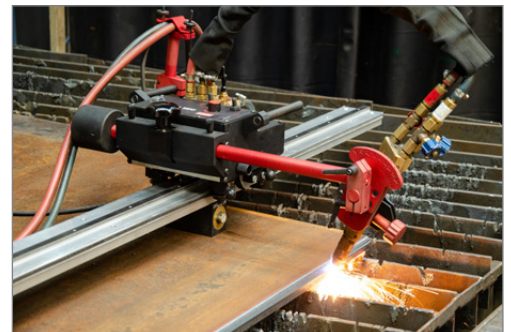

■ Standard accessories:



Power cord 3 m (9,7 ft)
PWD-0466-18-00-00-0 (230 V CEE)
PWD-0466-16-00-00-0 (115 V USA)
PWD-0466-23-00-00-0 (230 V UK)



Dual arc ignition cable 6.5 m (21 ft)
KBL-0466-17-00-00-0



540 mm (21") Geared Rack
RAM-0525-07-00-00-0



Cable anchor
UCW-0523-05-01-00-0



Rackholder
ZSP-0475-62-00-00-0



300 mm (12") rack
with 180 mm (7") adjustment
RAM-0523-17-00-00-0



Clamping block with levers
KST-0525-11-00-00-0



Short rod torch holder with fits-all clamp
UCW-0476-20-00-00-0

Optional accessories:



Gear Rack Adjustment Tool
PKT-0341-13-00-00-0



700 mm (27.6") Geared Rack
RAM-0475-07-03-00-0



Counterweight
1.3 kg (2.9 lbs)
PWG-0475-09-00-00-0



1000 mm (39.4") Geared Rack
RAM-0475-23-00-00-0



Large Counterweight
2,6 kg (5,7lbs)
PWG-0475-10-00-00-0



16-22 mm Torch Clip
ZCS-0476-06-01-00-0



22-35 mm Torch Clamp
ZRZ-0466-19-00-00-0



Standard Torch Holder
28-35 mm (1.10-1.38")
ZCS-0475-28-10-00-0



203 mm (8") rod
KLM-0236-00-16-00-0



Standard Torch Holder with angle adjustment
UCW-0475-28-00-00-0



Precise Torch Holder with angle and height adjustment
UCW-0475-08-00-00-0



Machine Barrel Torch Holder
Ø 30 mm (1.18")
UCW-0475-61-00-00-0



Machine Barrel Torch Holder
Ø 35 mm (1.38")
UCW-0475-29-00-00-1

Precise Machine Torch Holder
Ø 30 mm (1.18")
UCW-0475-59-00-00-0

Precise Machine Torch Holder
Ø 35 mm (1.38")
UCW-0475-42-00-00-1

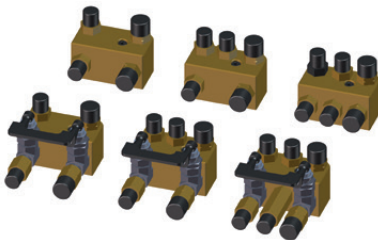

Gas Manifold type	Metric	Imperial
Manifold 2x2	RZD-0475-64-00-00-0	RZD-0475-68-00-00-0
Manifold 2x3	RZD-0475-63-00-00-0	RZD-0475-67-00-00-0
Manifold 3/3	RZD-0475-74-00-00-0	RZD-0475-73-00-00-0
Manifold 2x2 with cut-off valve	RZD-0475-65-00-00-0	RZD-0475-70-00-00-0
Manifold 2/3 with cut-off valve	RZD-0475-66-00-00-0	RZD-0475-69-00-00-0
Manifold 3/3 with cut-off valve	RZD-0475-72-00-00-0	RZD-0475-71-00-00-0

Hi-Flex tracks

For circumferential applications from 1500 mm (59") OD upwards

Hi Flex Track min OD 1500 mm
TRO-0673-00-00-00-0

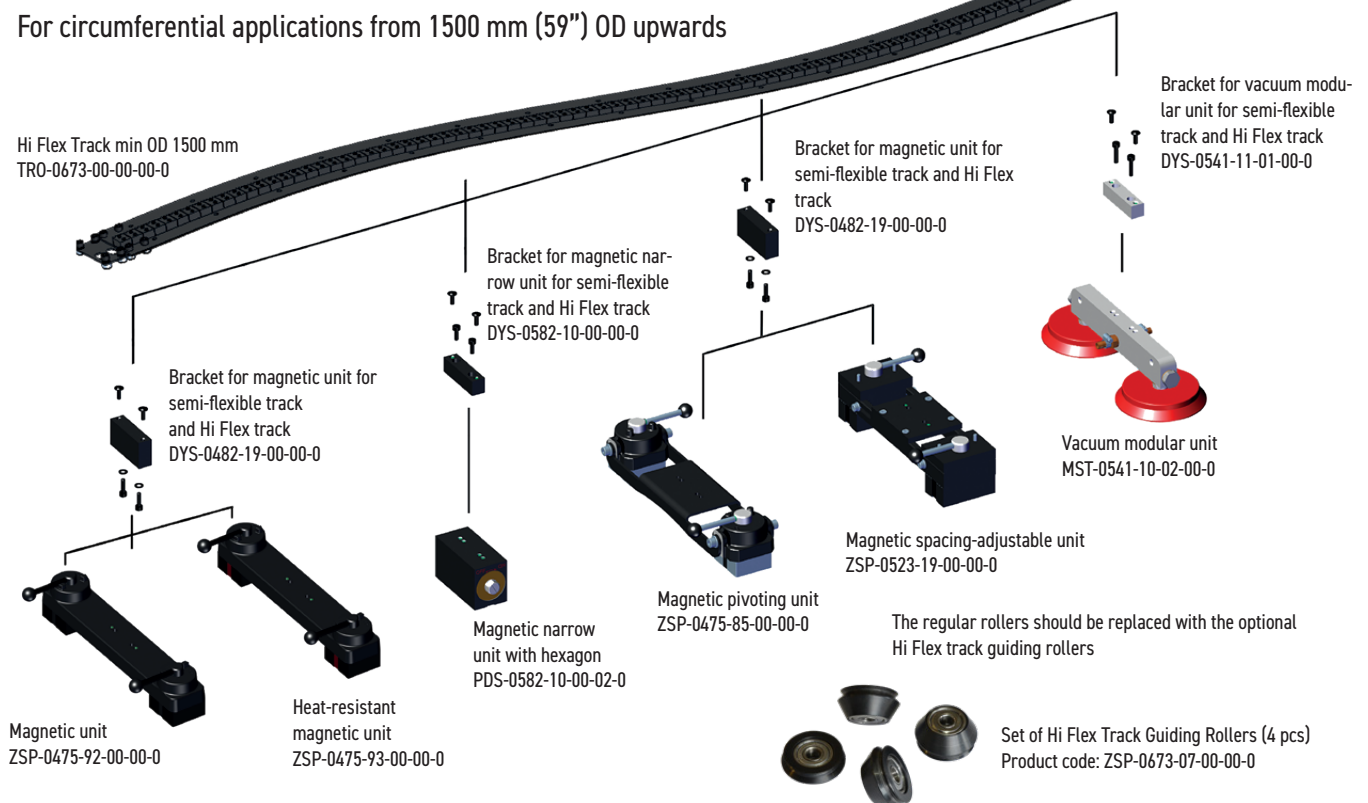

Ring tracks

For circumferential applications from 200 mm OD up to 3000 mm OD (from 8" to 10 ft.)

Ring tracks can be equipped with various supports depending on the customer's needs.

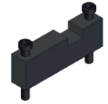
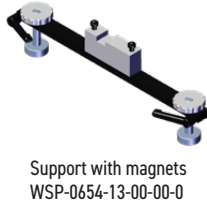

Bracket for ring track supports to expand pipe diameter range by 50 mm downwards
DYS-0523-14-14-00-0

Semi-flexible tracks

For straight line and circumferential applications. It can be flexed to minimum radius of 5 m (16 ft) without permanent deformation



Semi-flexible track length 2 m (6.5 ft)
PRW-0482-15-05-00-0

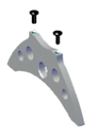
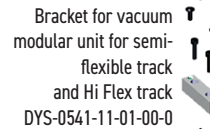
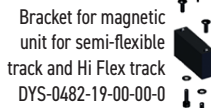
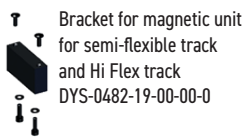
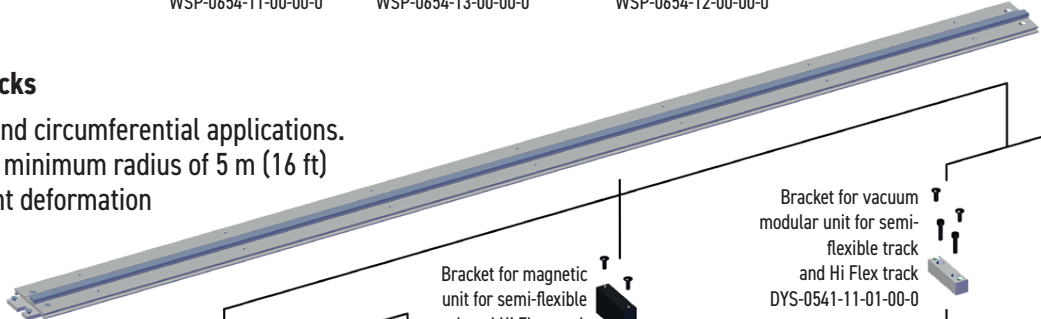

Aluminum track support for semi-flexible track
WSP-0541-11-02-00-0

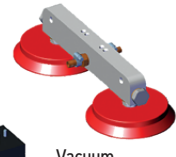

Vacuum modular unit
MST-0541-10-02-00-0

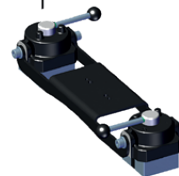

Magnetic pivoting unit
ZSP-0475-85-00-00-0

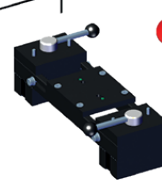

Magnetic spacing-adjustable unit
ZSP-0523-19-00-00-0



Steel track support for semi-flexible track
WSP-0523-12-01-00-1



Magnetic narrow unit with hexagon
PDS-0582-10-00-02-0

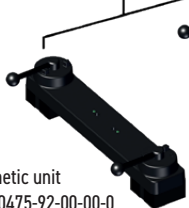

Magnetic unit
ZSP-0475-92-00-00-0



Heat-resistant magnetic unit
ZSP-0475-93-00-00-0

Rigid tracks

For straight line applications and for going beyond workpiece and continuous welding edge to edge

Rigid track length 2 m (6.5 ft)
PRW-0482-47-00-00-0

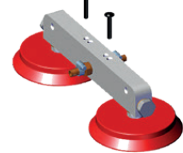
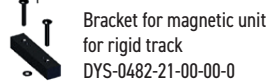
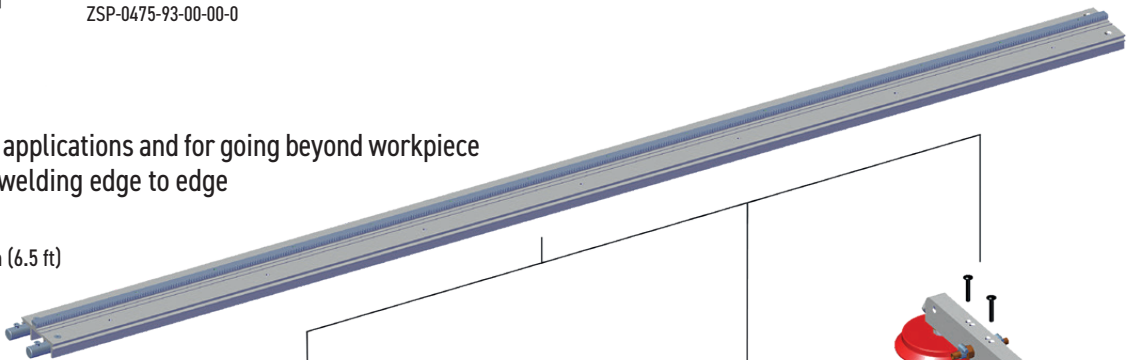

Vacuum modular unit
MST-0541-10-02-00-0

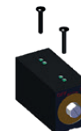

Magnetic narrow unit with hexagon
PDS-0582-10-00-02-0

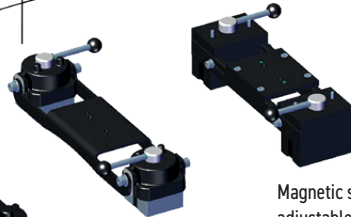

Magnetic spacing-adjustable unit
ZSP-0523-19-00-00-0

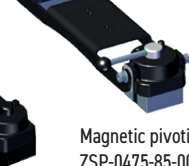

Magnetic pivoting unit
ZSP-0475-85-00-00-0



Heat-resistant magnetic unit
ZSP-0475-93-00-00-0



Lightweight Magnetic Unit
MST-0677-00-00-00-0



Magnetic unit
ZSP-0475-92-00-00-0



RAIL TUG Technical specification	
Voltage	1~ 115-230 V, 50-60 Hz
Power	66 W
Welding position (according to EN ISO 6947 and AWS/ASME)	PA / 1F / 1G PB / 2F PC / 2G PD / 4F PE / 4G PG / 3F (contact your dealer)
Fixing on pipes and round workpieces	Ring tracks Hi Flex tracks Semi-flexible track
Torch type	MIG/MAG, SAW, Plasma, Oxy-fuel
Torch diameter	MIG/MAG SAW, Plasma Oxy-fuel
Horizontal pulling force	300 N
Vertical pulling force	200 N
Horizontal speed	10-200 cm/min (4-80 in/min)
Vertical speed	10-200 cm/min (4-80 in/min)
Weight	10 kg (22 lbs)
Product Code (115-230 V, 50-60 Hz, plug EU)	WOZ-0570-10-20-00-0

Standard shipping set:

- Rail Tug tractor
- Cardboard box
- 300 mm (12") rack with 180 mm (7") adjustment
- Rack holder
- Clamping block with levers
- Short rod torch holder with clamp
- Cable anchor
- 6 mm hex wrench
- 6.5 m (21 ft) arc ignition cable
- 3 m (10 ft) power cord
- Operator's Manual

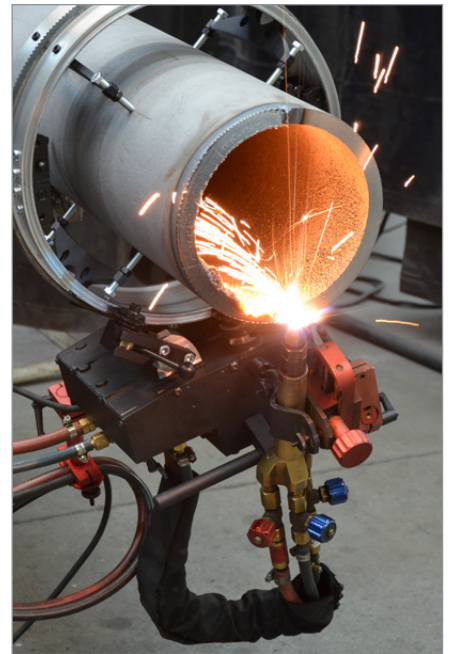

More information available at www.promotech.eu



All information is subject to change without notice. 23.03



PROMOTECH Sp. z o.o.
ul. Elewatorska 23/1, 15-620 BIAŁYSTOK, POLAND
tel. (+48 85) 678 34 05, fax (+48 85) 662 78 77
marketing@promotech.eu www.promotech.eu

Your local dealer:

